

## Second generation of large double fed induction motor generators

Werner Ladstätter, Alexander John, Manfred Kohlhofer, Philipp Leopold

ANDRITZ HYDRO GmbH, Austria

Double fed induction machines (DFIM) are a niche but a significant one in the area of electrical drives and electrical energy production with variable speed. This type has been widely used for wind generators in the past but typically replaced by full size converter applications. For pump storage plants large units in the area of 200 MW and higher in conjunction with variable speed have been installed mostly in Japan, before in 2004 the first units have been commissioned in Germany at that time by VA Tech, now belonging to Andritz Hydro.

DFIM motor generator solutions are a lot more complicated regarding its design and are used mainly due to two reasons: optimised operation for the turbine with significant varying water level at the upper reservoir and the possibility to vary power in pump mode. To allow variation in speed at constant grid frequency the flow direction of the slip power, its height and frequency must be altered, which is enabled by the two-way converter.

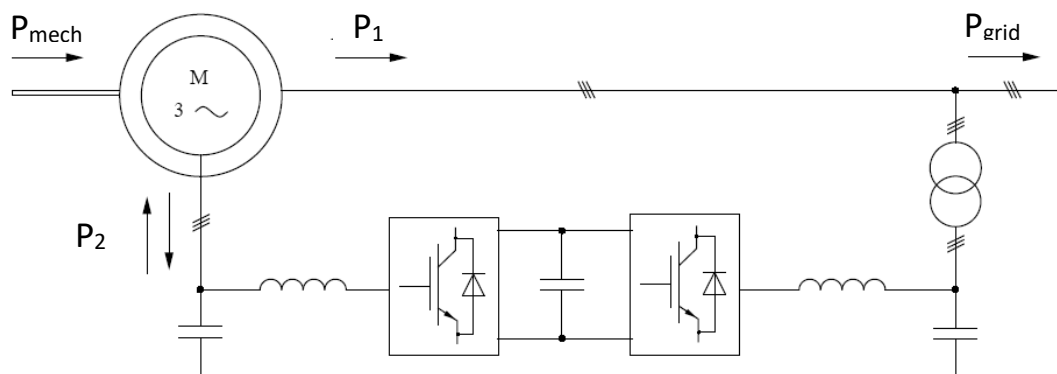

Since 2004, a few more units outside Japan are in operation, for instant in Slovenia, Portugal, Switzerland and India. Between 2004 and today two major market and technological impacts cause partly some design changes and enhanced calculation methods. Need to support a more fragile electrical grid due to heavy installed wind and solar power plants and the generator accident at Rotund in 2009 due to fatigue issues caused by frequent start-stop operation and load changes.

For the in future largest pump storage power plant in the world, located in the northeast of China, Andritz Hydro has been awarded to supply the only two double fed induction motor generators with each 336 MVA for the project Feng Ning, where a total electrical power of 3600 MW will be installed before the Olympic winter games in Beijing in 2022.

Whereas the stator of such DFIM is similar to synchronous generators, the rotor is entirely different from the design perspective. Lifetime requirements of 50 years along with 10 start- stops a day, speed variations from 400 – 460 rev/min and a load rejection speed of 640 rev/min end up in engineering masterstrokes at the very limit, what mechanical engineering is capable to design, manufacture, transport and to assemble. The rotor consists of a cylindrical shape with slots to embed the high voltage rotor winding in the active part. For the desired frequency variation of  $\pm 7.5\%$  in motor mode and 0 to  $-7.5\%$  in generator operation, thousands of Ampere pave their way from the converter to the slip ring and brush system to the Roebel bars of the rotor winding, which an operational voltage of 3.6 kV.

To hold the heavy weight of the rotor bars the pole sheets and the end winding design are absolute decisive for the integrity of the motor generator.

Pole sheets are normally made of material with predominantly mechanical properties (yield strength, Woehler curves and so on). For this application, alternating current and therefore alternating magnetic fields will create higher electrical losses and may be reduced in using electrical steel sheets with lower magnetic losses in line with lower mechanical properties. Both materials with pros and cons are possible and in this paper it will be described, how this ambiguity for this new project was solved.

Another very critical design feature is the end winding area of the rotor, where the weight of the protruding rotor bars with its connection and its circumferential forces during normal operation, no load and runaway speed as well as the high voltage of the rotor bars have to be merged into one highly sophisticated design. As the first application of the so-called retaining ring at the PSPP in Goldisthal has been very successful in the 14 years of operation, for Feng Ning the same concept will be used with some optimized features in terms of design and material.

As the basic concept is not finished in all details and no approval from the customer has been given for the overall design to date, it is not possible to give any graphics or charts in this abstract. These together with many more details in terms of technical challenges and design solutions will be shown in the paper version.

Contact:

Werner Ladstätter

Andritz Hydro

Dr. Karl Widdmann Strasse 5

8160 Weiz

AUSTRIA

Phone: +43 664 251 9161

[Werner.ladstaetter@andritz.com](mailto:Werner.ladstaetter@andritz.com)

**Werner Ladstätter, MBA** graduated in Electrical Engineering at the University in Graz, Austria. He worked several years for Alstom Power in Switzerland, where he started his career as an electrical design engineer and became later responsible for stator design of turbogenerators. In 2005 he took over the responsibility of the R&D department of High Voltage insulation at Isovolt Group in Austria. In June 2011 Mr. Ladstätter moved to ANDRITZ Hydro and has been in charge of R&D of hydro- and turbogenerators in Weiz-Austria and in 2015 he took the responsibility for the engineering of hydro generators in the same company.

Since 2008 he has been member of the IEC working group TC 2 / MT 10 for the “Qualification, Tests and Diagnostics of Winding Insulation Systems for Rotating Machines”.