



SEPARATION

RECOVERY OF HIGHLY CLARIFIED LIQUID

ANDRITZ THICKENING
AND CLARIFICATION SYSTEMS

ANDRITZ

ENGINEERED SUCCESS

In the most challenging applications, reliable liquid clarification and slurry recovery is critical to maintaining continuous production. This is why ANDRITZ has put decades of expertise into thickening and clarification systems to provide an efficient and cost-effective solution.

ANDRITZ thickening and clarification solutions are designed to achieve the highest production rates without compromising efficiency. For all counter-current decantation (CCD) plants, the new and improved ANDRITZ inter-stage mixing and dilution system for CCD circuits helps to reduce the footprint and consequently cut CAPEX while maintaining low operating costs. The innovative paste-thickener design facilitates highly clarified liquid recovery as well as maximum underflow densities.



Cost-effective solid-liquid separation with crystal clear overflow

The thickening and clarification systems from ANDRITZ Delkor (Pty) Ltd. make use of state-of-the-art sedimentation technology to offer an efficient and reliable solid-liquid separation unit for a variety of applications.

VARIETY AND AVAILABILITY

Thanks to the thickener's innovative, modular design, ANDRITZ is able to offer a wide range of thickeners and clarifiers with diameters from 1 to 70 meters. Along with an extensive range of construction materials, efficient dilution systems, and optimized flocculation options, this means we can provide a customized solution that is an ideal fit for your application.

ANDRITZ has decades of experience in designing, producing, and installing thickeners and clarifiers in a range of highly demanding industries.

MAIN APPLICATIONS INCLUDE:

- Copper/cobalt
- Uranium
- Coal
- Lead
- Zinc
- Iron ore
- Industrial effluents
- Clarifying of underground mud
- Lithium
- Potash
- Phosphate
- Phosphoric acid



High-rate thickener for coal, 20 m in diameter



Phosphoric acid clarifiers, 30 m in diameter

Latest sedimentation technology with unique design features

ANDRITZ makes use of the latest sedimentation technology to offer unique design features that can be customized to suit your application for optimum thickening and clarification.



- 1 Deaeration tank:** Specially designed to reduce air entrainment in order to minimize turbulence and flocculant shearing in the feed pipe.
- 2 Evenflow 2.0 feedwell:** The newly improved feedwell reduces turbulence by using guiding fins for enhanced flocculation.
- 3 Dilution systems:** This system facilitates optimized dilution without disturbing the mud bed and yet is still versatile enough to take upstream process changes into account. ANDRITZ thickeners can be supplied with an internal (GR or NT) or external (XT) dilution system.
- 4 Scum suppression:** Various scum suppression methods are available to ensure clear overflow.
- 5 Drive mechanism:** A wide range of hydraulic and electric drive mechanisms are available to meet torque requirements.





YOUR BENEFITS

- High throughput with optimized underflow density, flocculant consumption, and overflow clarity
- Reduced downtime due to innovative feedwell design
- Global manufacturing facilities
- Global testing facilities
- Minimal site construction work thanks to hybrid bolted design
- Global service centers



Targeted range to meet your requirements

The ANDRITZ thickener range has been designed to meet your needs and constraints in the mining, minerals, and chemical industries.

Depending on your process conditions and settling requirements, the timeframe for your installation, flexibility, and other criteria, we have the correct,

optimized solution to suit your needs. Digital twin technology is available for all ANDRITZ Thickeners.

ANDRITZ THICKENERS

ANDRITZ EcoSET THICKENER

- Cost-efficient thickener range
- Light to medium duty solid-liquid separation
- Reduced delivery time

ANDRITZ GeoSET THICKENER

- Standard pre-engineered thickener range
- Range caters for most process requirements
- A wide variety of options can be added to this range

ANDRITZ LiKOSET THICKENER

- Engineered specifically for the lithium and potash markets
- Manufactured from duplex steel for added strength, chemical-resistant

ANDRITZ CUSTOM THICKENER

- Suited for process specifications
- Engineered to order based on site and client specifications
- Heavy-duty paste thickeners are also available





ANDRITZ EcoSET THICKENER

ANDRITZ EcoSET is a cost-efficient thickener range that handles light- to medium-duty solid-liquid separation. With its plug-and-play control system, the ANDRITZ EcoSET thickener is a modular and standardized unit that reduces engineering requirements and delivery time.



ANDRITZ GeoSET THICKENER

ANDRITZ GeoSET is our standard thickener range, with an advanced modular design that is robust for life and provides maximum efficiency. The ANDRITZ GeoSET thickener can be supplied with a Metris addIQ control system.



ANDRITZ LiKOSET THICKENER

ANDRITZ LiKOSET is an industry-specific designed thickening solution targeting the ever-growing lithium and potash markets. The robust duplex stainless steel design means that it can be used in more harsh chemical applications as well.

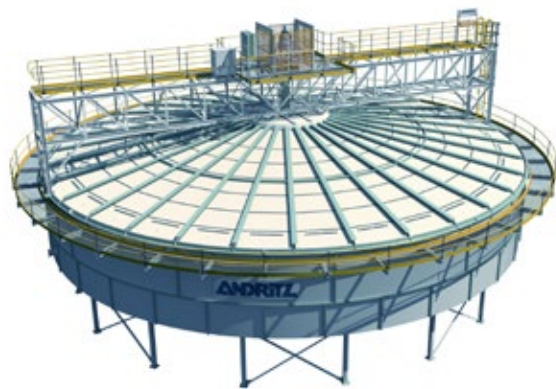

CUSTOM ANDRITZ THICKENERS

With the assistance of qualified separation specialists at ANDRITZ, customers have the option of fully customizing their thickeners to exactly suit their process specifications.

ANDRITZ BOLTED THICKENER

ANDRITZ thickeners can be supplied as a bolted version (depending on the model) to minimize site installation work. This innovative, modular hybrid design complies with international laws, regulations, and standards.



High-rate bolted thickener for iron ore, 18 m in diameter

YOUR BENEFITS

- Fast and easy assembly on site, no welding or touch-up paint required
- Standard bolted parts are interchangeable, making maintenance and repairs much easier, less downtime
- Standard bolted parts allows for the moving of feed and overflow nozzles to the desired positions around the thickener



High-rate bolted thickener for Pb/Zn tailings, 35 m in diameter

Additional thickening solutions to meet all your requirements

Over 50 years of thickening experience enables ANDRITZ to offer clients a wide range of solutions in these very demanding markets.



MIXING AND COUNTER-CURRENT DECANTATION (CCD)

- High levels of closed-circuit dilution counteract the negative effects of surging underflow pumps
- Bulk closed-circuit dilution technology (35% to 5% solids) using thickener overflow taken from the overflow weirs
- Consistent underflow quality
- Efficient washing in CCD circuits



ANDRITZ DEEP-CONE SETTLER

The ANDRITZ deep-cone settler is designed for heavy duty activities, mainly for applications above and below ground. It is very simple to operate and provides the following features and benefits:

- Effective gravitational settling for high-density solid particles
- No internals or moving parts
- Low power consumption
- Optimized footprint size for maximum separation
- Bolted or welded structure



PASTE TECHNOLOGY

ANDRITZ paste thickeners incorporate:

- High side walls, steep tank floors and unique feedwell design to enhance settling and promote paste formation to maximize underflow densities.
- Specialized low-profile rake design that encompasses a unique underflow cylinder scraper to ensure sheer thinning of the underflow and prevent the underflow mud bed from solidifying

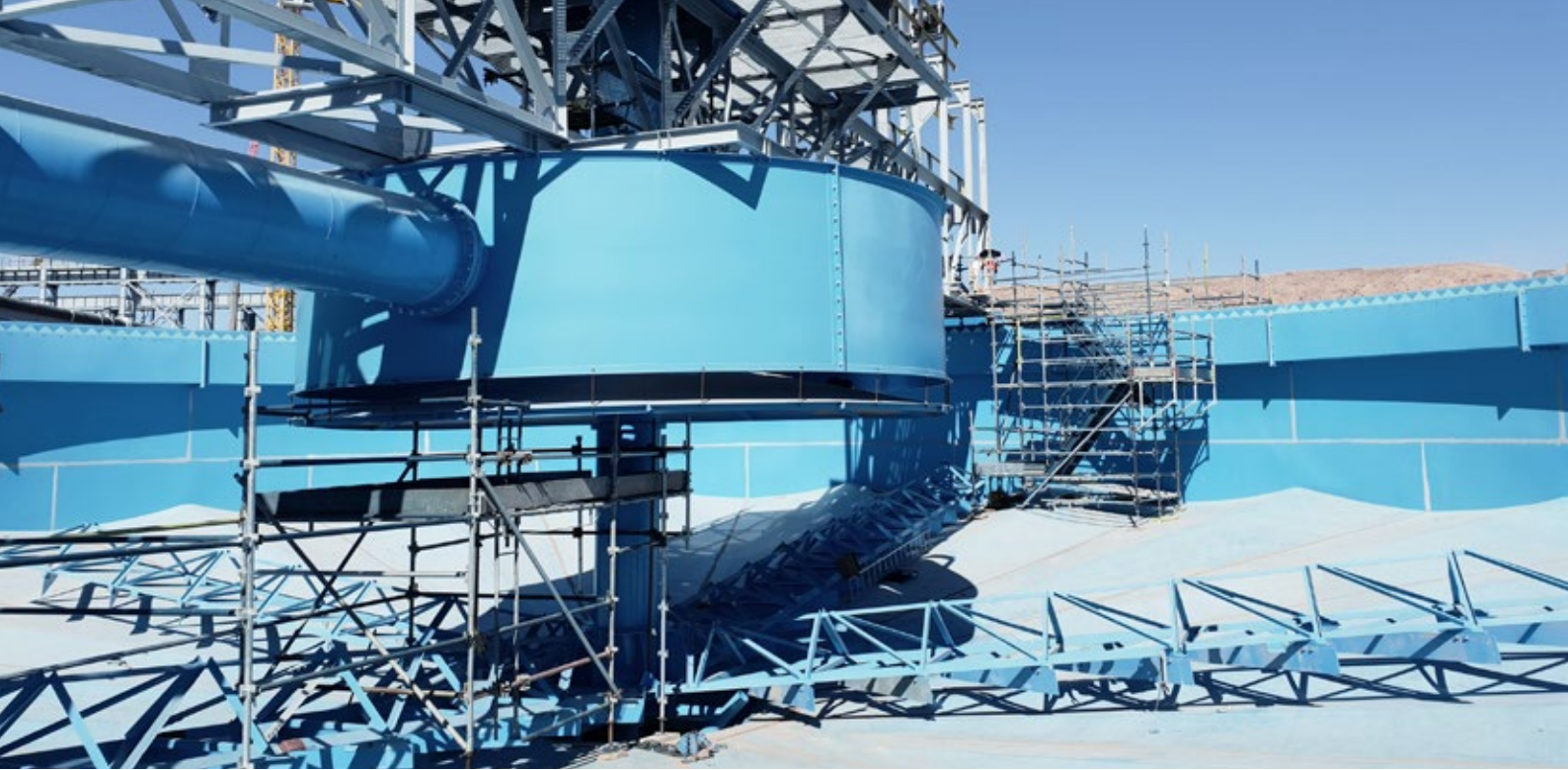

Evenflow feedwell 2.0: Improvement through research and development

The first stage of the Evenflow feedwell dissipates the kinetic energy in the incoming feed by slowing it down. This kinetic energy is used to mix the dilution water (if required) and flocculant into the slurry homogeneously in order to achieve optimum density and flocculation. In the second stage of the feedwell, the flocculated slurry is maintained under lower shear stress to enable suspended particles to aggregate into floc chains.

Finally, the flocculated slurry exits from the feedwell via the deflector plate, which is designed to ensure even and optimum distribution into the thickener.

The benefits of the new and improved Evenflow feedwell are plain to see:

- Optimum flocculant consumption by enhancing residence time within the feedwell
- Controlled slurry distribution within the feedwell by incorporating fins to prolong flocculant contact time
- Low operating costs
- Elimination of choking by including a deflector plate scraper and clover outlets
- Reduced downtime for maintenance work

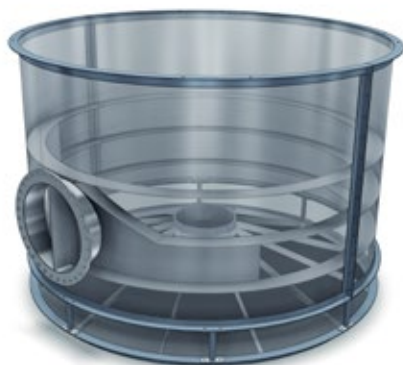

Overview of Evenflow feedwell 2.0

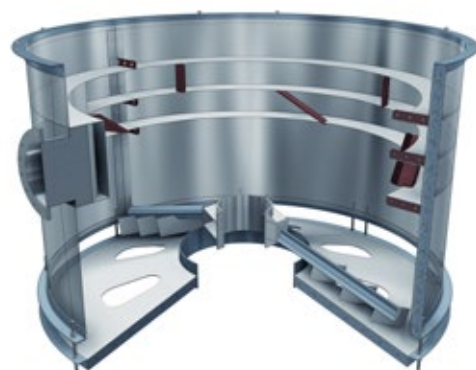

Cross-section of Evenflow feedwell 2.0



Optimized settling rate with efficient dilution system

Dilution means reducing the concentration of solute in a solution by simply adding more solvent. This dilution step guarantees a perfect solid-liquid ratio in the feed to enhance the settling rate once flocculants are added. Flocculants are more effective if added to a perfect solid-liquid ratio.

ANDRITZ dilution system GR

- Internal dilution system
- Flow rate: 0–2,600 m³/hr
- Located inside the tank
- Situated at a distance that will not hinder free settling rate or mud bed formation
- Easy to retrofit
- Flexible overflow nozzle position
- Adjustable flow rate

ANDRITZ dilution system XT

- External dilution system
- Flow rate: 2,800–15,000 m³/hr
- Located outside the thickener tank
- Allows for large dilution rates
- Better mixing capabilities
- Flexible overflow nozzle position
- Adjustable flow rate

ANDRITZ dilution system NT

- Internal dilution system
- Flow rate: 600–9,000 m³/hr
- Uses overflow liquid to dilute incoming slurry to the required solid-liquid ratio
- Classified as internal dilution, which means that the entire system is located inside a thickener tank and makes use of internal overflow liquor for dilution purposes.
- Does not interfere with thickener settling process
- Adjustable flow rate
- Can accommodate slurries with low pH values



ANDRITZ dilution system GR

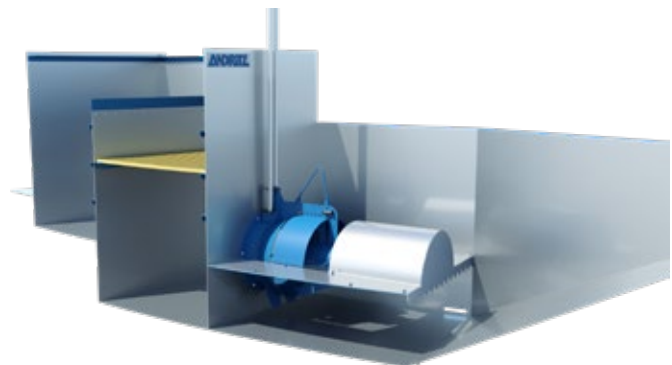

ANDRITZ dilution system NT



Offering the entire range of drive heads

ANDRITZ drive heads range from small direct drives to large ring gear and pinion drives of up to 8,100 kNm.

The drive head rotates a low-profile raking mechanism effortlessly inside the thickener, moving the settled solids towards the discharge cone while also increasing solids density.

The drive head has several levels of safety, including high torque alarm, automatic rake mechanism lifting up to 600 mm, electrical tripping, and mechanical safety stop (either pressure-relief valve for hydraulic or clutch for electric stop).

The ANDRITZ drives have a heavy-duty design that will ensure many years of low-maintenance operation.

ANDRITZ has re-launched its entire range of drive heads in response to the industry's ever-increasing need for cost-effective, durable, and low-maintenance units:

- Extensive range of drive head designs
- Hydraulic and electric drive
- 360-degree inspection access in and around the drive head
- Fully automated drive control including auto-load sensing on drives for consistent underflow quality
- Hydraulic units with reversible or variable speeds

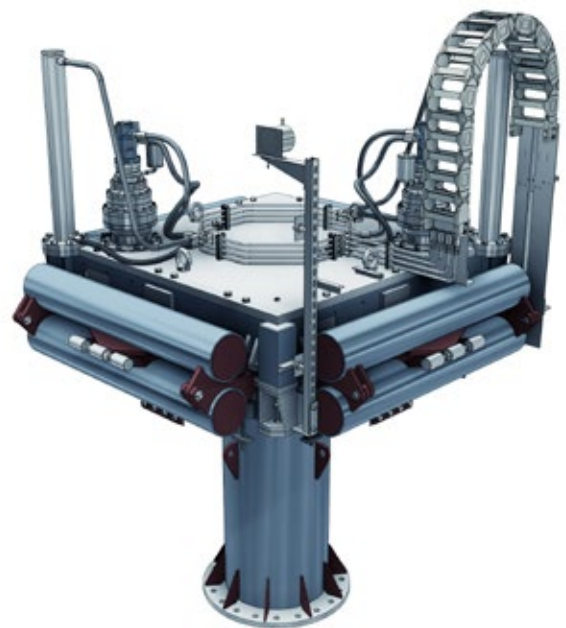

ANDRITZ drive heads

Most effective and technically viable system thanks to added services

ANDRITZ is the OEM of tried-and-tested technologies for all major industries. With more than 45 years of experience in designing, installing, and testing thickeners in a variety of applications, ANDRITZ has a comprehensive reference list spanning both local and international markets.

LABORATORY TESTING FACILITIES

ANDRITZ's own laboratory testing facilities in multiple locations across the globe complete the range of services. These facilities offer a series of standard settling tests as well as tests that include:

- Compaction/time curves
- Slump test
- Maximum gravitational compaction tests and rake action testing

ANDRITZ is able to offer dynamic testing, including batch, semi-batch, and continuous methods for fine tuning of the laboratory results. Based on the laboratory and dynamic test results, ANDRITZ provides a design that allows clients to evaluate their optimum deposition scenario.

And that's not all – ANDRITZ also offers on-site pilot plant work and assistance in verifying material characteristics and rheology.

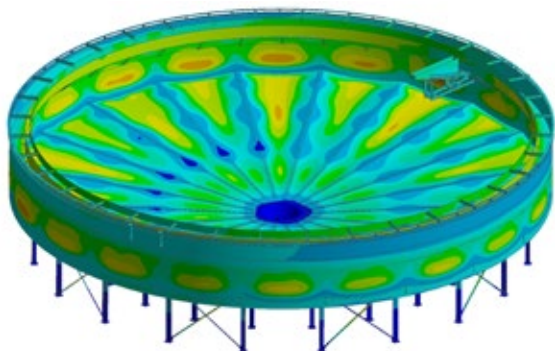

ANDRITZ thickener FEA

ENGINEERING TECHNOLOGIES

During the development of new-generation thickeners, ANDRITZ has implemented the most modern engineering technologies.

- Computational fluid dynamic (CFD) modelling of process parameters
- Finite element analysis (FEA) for optimum weight/stress ratio
- Dynamic simulation of thickeners and CCD circuits for optimized performance using the IDEAS simulation package
- Dynamic earthquake evaluations
- Hydrodynamic response to earthquake loading
- 3D parametric modelling
- Detailed lifecycle calculation of all mechanical components, guaranteeing 100,000 hours of operation or longer if necessary

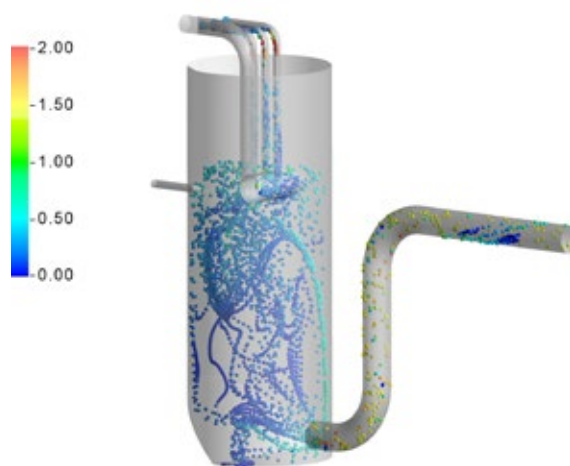

ANDRITZ deaeration tank CFD

Intelligence for machine and process control

With Metris addIQ, you have a well-proven, intelligent control solution for industrial processes and machines. Our solid/liquid separation specialists use their in-depth expertise to provide scalable solutions that are individually tailored to regional and application requirements. Whether you're automating new equipment or upgrading to extend the lifecycle of existing systems, we find the ideal solution for you.

METRIS addIQ CONTROL SYSTEMS

Our tailored turnkey systems from a single supplier can improve entire plants or individual machines. By providing state-of-the-art automation technologies and digitalization, we ensure best-in-class performance. Automating machine and plant equipment measurably reduces gaps in many different production process steps. By using automation from ANDRITZ, you can reduce downtime thanks to features such as predictive analysis that allow you to optimize productivity.

Metris addIQ covers all levels of automation, starting at basic automation (machine, process, and plant control), to upgrades, and add-ons for process optimization. Together, you have a full range of optimized solutions that help reduce maintenance efforts and ensure preventive service for your machines and plants. These are all delivered from a single source and always individually tailored to your business demands. addIQ control systems are part of Metris, the ANDRITZ brand for digital solutions.

ANDRITZ offers a broad and constantly growing range of innovative products and services in the industrial digitalization sector under the brand name Metris, helping customers to enhance plant efficiency and profitability, optimize the use of resources, achieve constant and highest product quality, reduce production downtime, and maximize user-friendliness.



Your full-service provider

With ANDRITZ, you gain access to one of the world's largest OEM manufacturers for solid/liquid separation systems, including such well-known brands as 3Sys Technologies, Bird, Delkor Capital Equipment (Pty) Ltd., Escher Wyss dryers, Guinard Centrifugation, KHD Humboldt Wedag, Krauss-Maffei centrifuges, dryers, and filters, Lenser, Netzsch Filtration, Rittershaus & Blecher, Royal GMF Gouda, Sprout Bauer, and Vandebroek.

Whether you need spare parts, rentals, local service, repairs, upgrades, or modernization of your equipment, ANDRITZ is your true full-service provider. From initial consulting through to service agreements, process optimization, and training programs, we are always looking for ways to minimize downtime and increase

predictability in operations while raising your overall production efficiency. Wherever you operate, our network of 550 service specialists and global service centers ensures we'll always be there to support you for many life cycles to come. Let's sit down and see how we could take your operations to the next level.



LOCAL SUPPORT

Responsive local service centers and field service technicians



REPAIRS & UPGRADES

Optimization of machine and process performance, repair work, retrofitting, and modernization



SECOND-HAND & RENTALS

Certified second-hand and rental machines



TRAINING

Operator training and tailored seminars for operating and maintenance personnel



OEM SPARE PARTS

Filter cloths, spare and wear parts from OEMs or with OEM level quality, all readily available



SERVICE AGREEMENTS

Preventive maintenance, contracts for spare parts, maintenance, inspections, repairs, upgrades, operation, and equipment monitoring



PROCESS OPTIMIZATION

Automation tools and process expertise to boost your profit



LAB AND ON-SITE TESTS

Lab and testing capabilities for process optimization and machine upgrades





WHAT'S YOUR SEPARATION CHALLENGE?

ANDRITZ Separation is the world's leading separation specialist with the broadest technology portfolio and more than 2,000 specialists in 40 countries. For more than 150 years, we have been a driving force in the evolution of separation solutions and services for industries ranging from environment to food, chemicals, and mining & minerals. As the OEM for many of the world's leading brands, we have the solutions and services to transform your business to meet tomorrow's changing demands – wherever you are and whatever your separation challenge. **Ask your separation specialist!**

AFRICA

ANDRITZ Delkor (Pty) Ltd.
p: +27 11 012 7300
separation.za@andritz.com

EUROPE

ANDRITZ AG
p: +43 316 6902 2634
separation@andritz.com

ASIA

ANDRITZ Singapore Pte. Ltd.
p: +65 6512 1800
separation.sg@andritz.com

NORTH AMERICA

ANDRITZ Separation Inc.
p: +1 817 465 5611
separation.us@andritz.com

AUSTRALIA

ANDRITZ Pty. Ltd.
p: +61 3 8773 4888
separation.au@andritz.com

SOUTH AMERICA

ANDRITZ Separation Ltda.
p: +55 47 3387 9100
separation.bra@andritz.com

CHINA

ANDRITZ (China) Ltd.
p: +86 757 8258 6802
separation.cn@andritz.com

[ANDRITZ.COM/SEPARATION](https://www.andritz.com/separation)

JOIN US ON SOCIAL MEDIA



ANDRITZ

All data, information, statements, photographs, and graphic illustrations in this leaflet are without any obligation and raise no liabilities to or form part of any sales contracts of ANDRITZ AG or any affiliates for equipment and/or systems referred to herein. © ANDRITZ AG 2022. All rights reserved. No part of this copyrighted work may be reproduced, modified, or distributed in any form or by any means, or stored in any database or retrieval system, without the prior written permission of ANDRITZ AG or its affiliates. Any such unauthorized use for any purpose is a violation of the relevant copyright laws. ANDRITZ AG, Stattegger Strasse 18, 8045 Graz, Austria. PB Thickener 3.0/10.2022 EN